



Vehicle Restraint Installation Manual

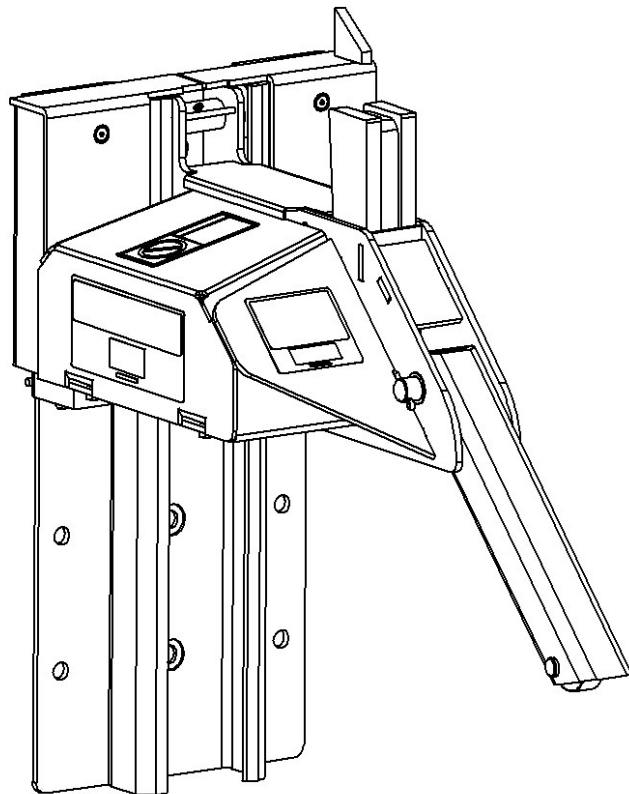

TABLE OF CONTENTS

	PAGE
SAFETY WARNINGS	3
PARTS IDENTIFICATION	4
INSTALLATION INSTRUCTIONS	4
WARRANTY	11

Nova Technology engages in ongoing product development and reserves the right to make changes and improvements to any of the products described in this document without prior notice.

SAFETY WARNINGS

You will find the safety alerts DANGER, WARNING, CAUTION or NOTICE used throughout this manual. Their meaning is listed below:

 DANGER
This is the highest level statement. Failure to follow the listed instructions will most likely result in death or serious injury.

 CAUTION
The statements used with this level of warning deal with a safe operating procedure. If the procedure is ignored the possibility of personal injury may exist.

 WARNING
This is a statement of serious hazard. Failure to follow the listed instructions could place the individual at risk of death or serious injury.

NOTICE
IMPORTANT is used to draw attention to a procedure that needs to be followed to prevent machine damage.

Be certain to follow the installation instructions in this manual; improper installation of the NOVA Lock-Up™ Vehicle Restraint could result in death or serious injury.

READ AND FOLLOW THE OPERATING INSTRUCTIONS IN THE OWNER'S MANUAL PRIOR TO OPERATING THE NOVA LOCK-UP™ VEHICLE RESTRAINT. Do not use the NOVA Lock-Up™ vehicle restraint if it is not working properly.

INSTALLATION INSTRUCTIONS

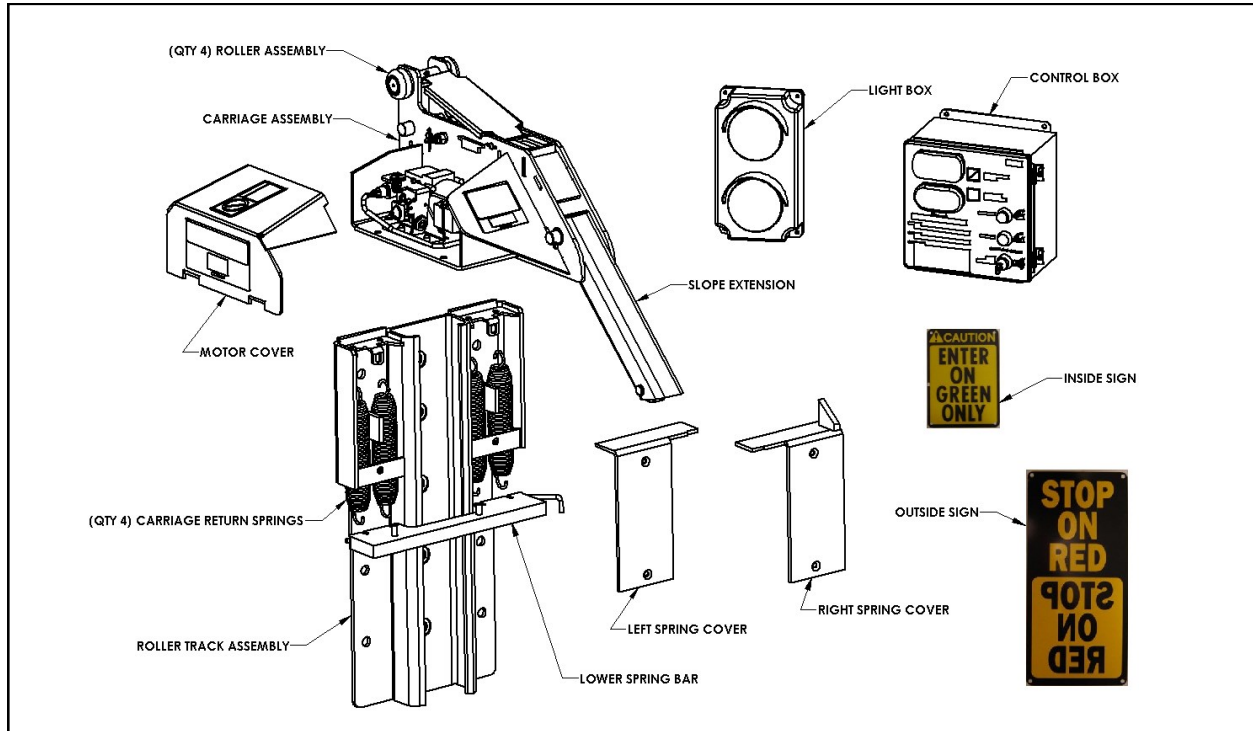

FIGURE A — PARTS IDENTIFICATION

NOTICE

A 4" thick bumper is required regardless of whether or not there is a leveler. **DO NOT** install a NOVA Lock-Up™ vehicle restraint on docks without 4" thick bumpers. For thicker bumpers consult factory.



DANGER

Post safety warnings and barricade work area, at dock level and at ground level, to prevent unauthorized use of the dock position.

INSTALLATION INSTRUCTIONS

A NOVA Lock-Up™ vehicle restraint may be installed on docks with or without levelers; consult NOVA for proper application.

Follow the simple installation procedures below:

- Inspect NOVA Lock-Up™ vehicle restraint parts.
- Install roller track plate.
- Install NOVA Lock-Up™ vehicle restraint into roller track plate.
- Install electrical components.
- Install safety & instruction signs.
- Test operation.

INSPECT NOVA LOCK-UP™ PARTS

Open packaging and inspect all parts and materials — see Figure A above. Immediately report any damage or missing materials to factory. Review the component assemblies to determine their correct locations.

INSTALLATION INSTRUCTIONS *continued*

INSTALL ROLLER TRACK PLATE

Install roller track plate onto dock face at specified location by welding to an embedded steel plate or by using the fifteen (15) concrete anchors provided in conjunction with welding to pit steel and a leveler frame. Refer to Figures B and C.

If you have questions, contact NOVA Technical Support at (800) 236-7325.

NOTICE

The roller track plate must be plumb with dock face. If not, use and weld (6) shims 2" wide x 25 5/8" long. If shims are over 1/2" thick use longer anchors. If shims need to be 1" thick or more, contact NOVA.

If the dock face is not perpendicular, contact NOVA Technical Support at (800) 236-7325.

The carriage roller track cannot be bent or deformed. Straighten or replace if necessary.

NOTE: Trim roller track plate, as necessary, up to a maximum of 5" from the bottom.

NOTE: Some mechanical dock levelers have an adjusting nut access hole in the leveler front subframe. If the NOVA Lock-Up™ vehicle restraint roller track interferes with the access hole, the track plate must be cut to allow access.

NOTE: Some levelers are slightly recessed within the pit and thus require a shim to be inserted between the roller track plate and the leveler front subframe and welded in place.

NOTICE

Fifteen (15) concrete anchors are provided with each NOVA Lock-Up™ vehicle restraint. An anchor must be installed in each roller track plate hole except for those plug-welded to embedded steel.

ANCHOR INSTALLATION INSTRUCTIONS

1. Put roller track plate in place.
2. Drill hole of 5/8" diameter and minimum of 4-5/8" deep. Clean out hole.
3. Insert anchor and drive flush with roller track plate, making sure that the threaded wedge is inserted first. Do not disassemble anchor prior to installation.
4. Install all anchors and torque to 100 ft-lbs. See figure B.

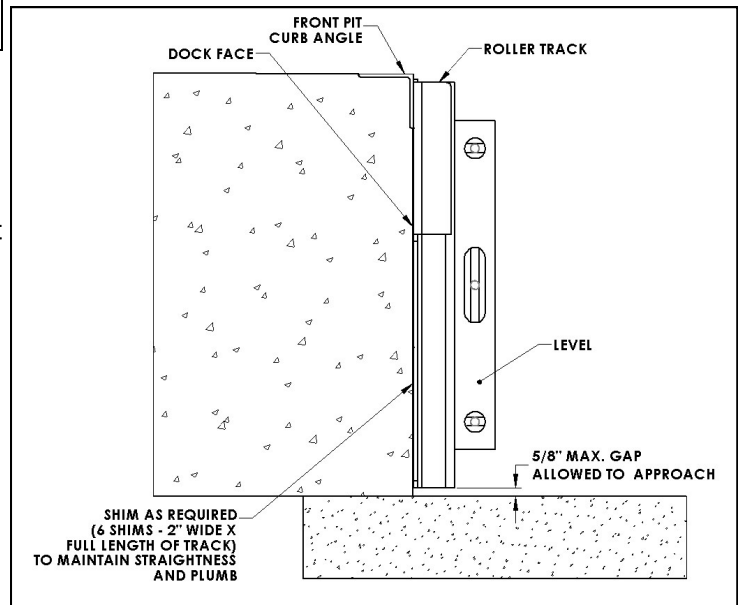

Figure B—Anchoring Roller Track Plate

INSTALLATION INSTRUCTIONS *continued*

WELDING INSTALLATION INSTRUCTIONS

If the installation being worked on is a retrofit or replacement situation, the following electrical connections must be disconnected prior to welding:

LOCKOUT/TAGOUT the power at the fused disconnect, then remove the motor and limit switch connections from the control harness located in the outside junction box. Once all welding has been completed, reconnect all the wires.

NOTES:

- Never install the NOVA Lock-Up™ vehicle restraint directly onto concrete block or brick dock face.
- When welding the NOVA Lock-Up™ vehicle restraint, disconnect power and ground leads to leveler.
- Due to actual conditions, total mounting height may be different.
- Plug weld all holes that are in contact with the embedded mounting plate. All fifteen (15) holes must be either plug welded or anchored. See figure C.
- Shims must be the full length of the roller track mounting plate. Minimum electrode must be 1/8" 7018 or better. See figure D.

NOTICE

Never weld on the NOVA Lock-Up™ vehicle restraint after the motor is wired into the control box and power to the control box is on. Electrical current from the welder can loop back through the circuit and damage the motor and other components.

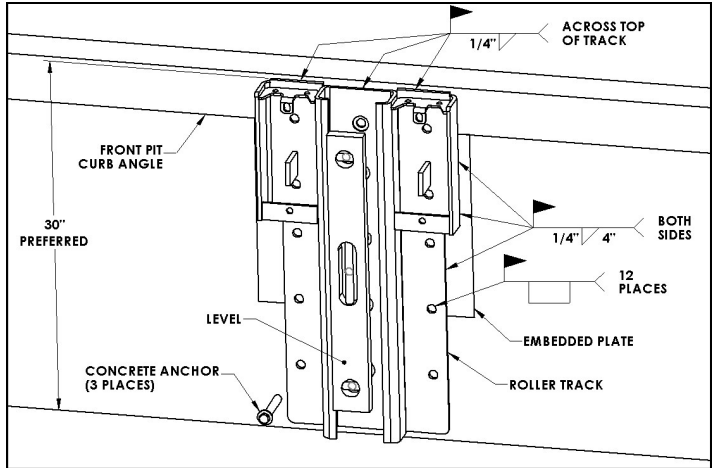

FIGURE C—WELDING ROLLER TRACK (WITH EMBEDDED PLATE)

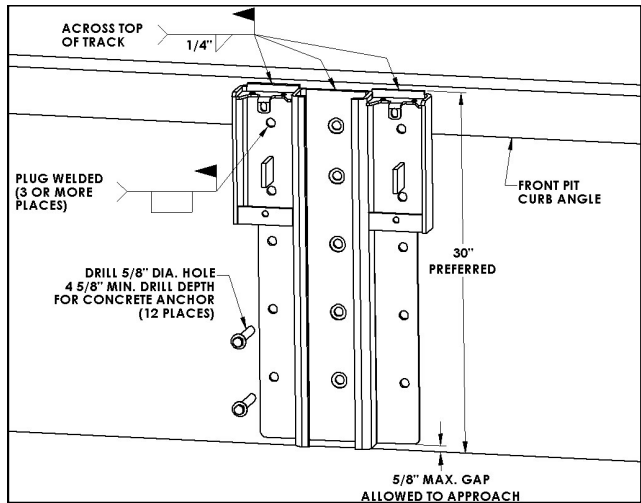

FIGURE D—WELDING ROLLER TRACK

INSTALLATION INSTRUCTIONS *continued*

INSTALL VEHICLE RESTRAINT INTO ROLLER TRACK PLATE



CAUTION

Use lifting device (e.g. crane, jack) when lifting carriage (approx. 105 lbs.). Lifting by hand may cause back injury.

- Attach the four (4) springs to the lower spring bar.
- Pull springs upward and slide over top spring mount on the track roller plate.
- Install right and left spring cover with U-Style cage nuts and flat head screws provided.
- Slide the carriage assembly into the roller track. Refer to Figure E.
- Position and bolt the lower spring bar to the bottom of the NOVA Lock-Up™ vehicle restraint carriage.
- Install the motor cover and spring covers.
- Install slope extension.

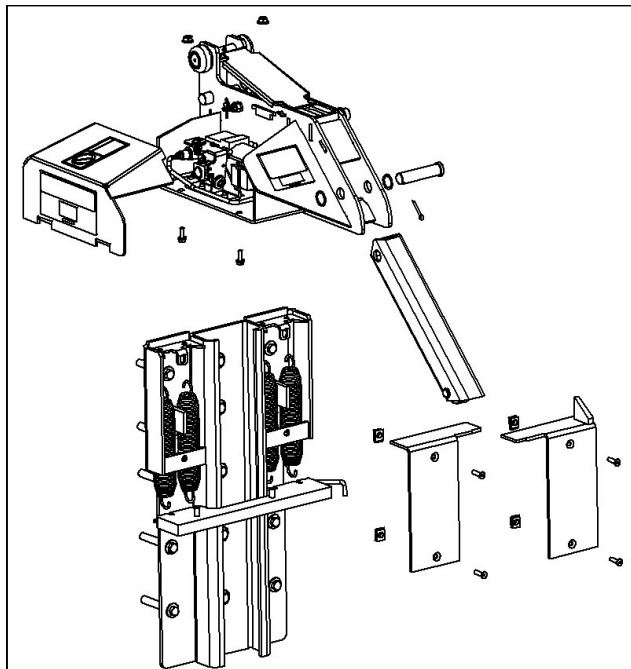

FIGURE E

INSTALLATION INSTRUCTIONS *continued*

INSTALL ELECTRICAL COMPONENTS

DANGER

Make sure that the power source has been locked out and tagged according to OSHA regulations and approved local electrical codes.

If the incoming electrical power for the NOVA Lock-Up™ vehicle restraint is taken from a nearby electrical appliance, e.g., overhead door opener, verify that the amperage is in accordance with local and federal codes.

The NOVA Lock-Up™ vehicle restraint 1/10 HP motor requires 120V, single phase power, 60 Hz power and 3 amps of current to operate properly.

Three (3) NOVA Lock-Up™ vehicle restraints can be connected into one (1) 20 amp branch circuit breaker per the 1999 National Electrical Code Paragraph 430-53.

If you have questions, contact NOVA Technical Support at (800) 236-7325.

NOTICE

Where indicated, all components must be connected to a **SAFETY EARTH GROUND** that conforms to the 1999 National Electric Code Section 250-50 section (a) or section (c) for a grounding electrode system.

The NOVA Lock-Up™ vehicle restraint assembly includes a 63" long flexible wiring harness, the control box with lights and the outside signal light box. The outside junction box, conduit fittings and wire are provided by others; be sure to use a qualified installer utilizing quality materials. Refer to Figures F and G.

Refer to Figure H, page 10 for component location information. Electrical schematics for wiring information can be found inside the control box.

CONTROL BOX INSTALLATION GUIDELINES - TEMPERATURE CONTROLLED APPLICATIONS.

1. Route the conduit to enter through the side or bottom of the enclosure. If the conduit could fill with water, a drip leg may be needed.
2. Seal the conduit in any location where the conduit crosses over temperature zones that could produce condensation.
3. Install spacers between the wall and enclosure to provide temperature insulation and air flow.

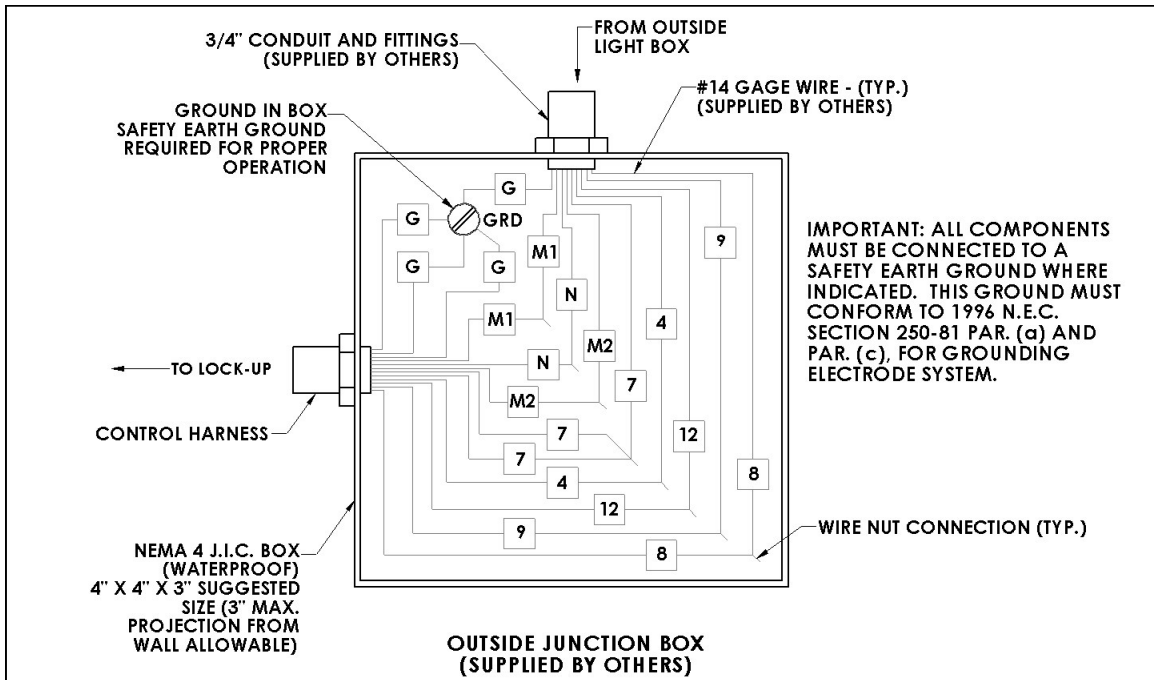

FIGURE F

INSTALLATION INSTRUCTIONS *continued*

INSTALL ELECTRICAL COMPONENTS *continued*

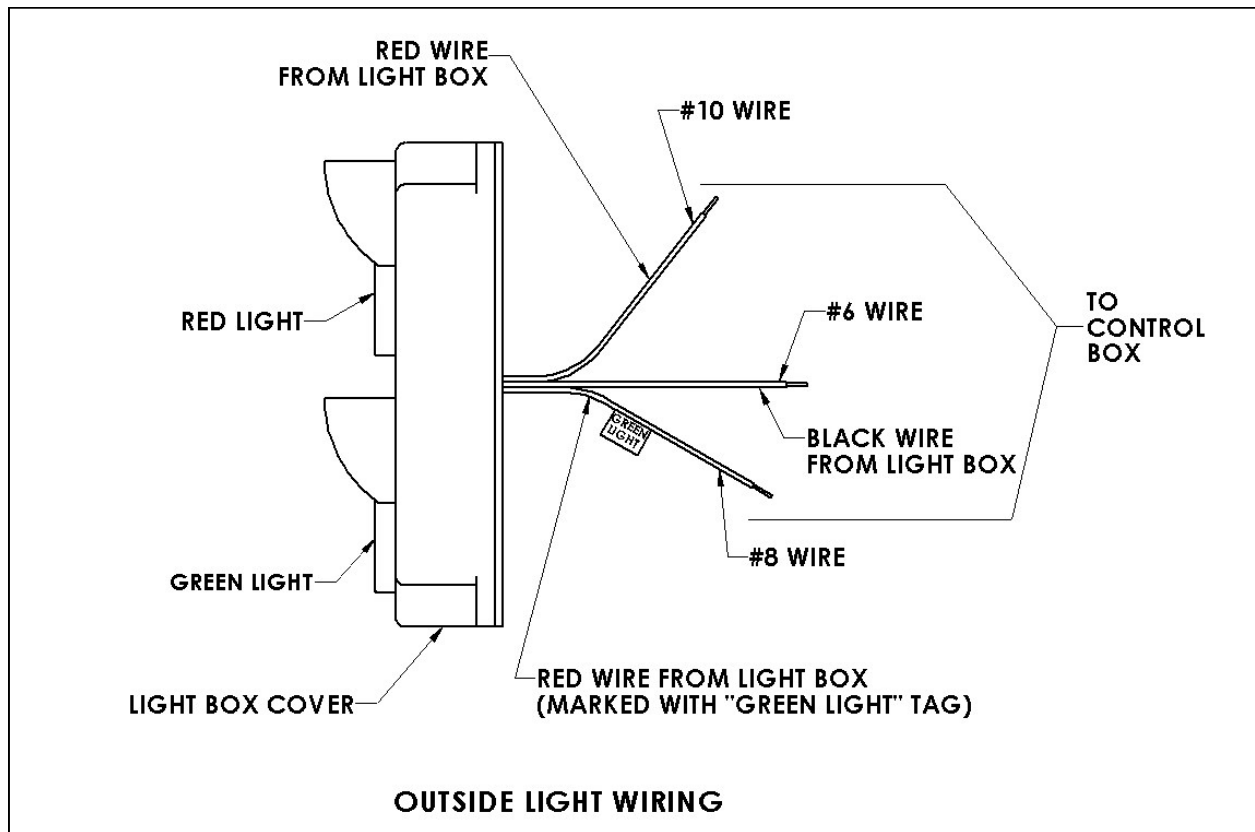

FIGURE G—OUTSIDE LIGHT BOX WIRING

INSTALLATION INSTRUCTIONS *continued*

INSTALL SIGNAGE

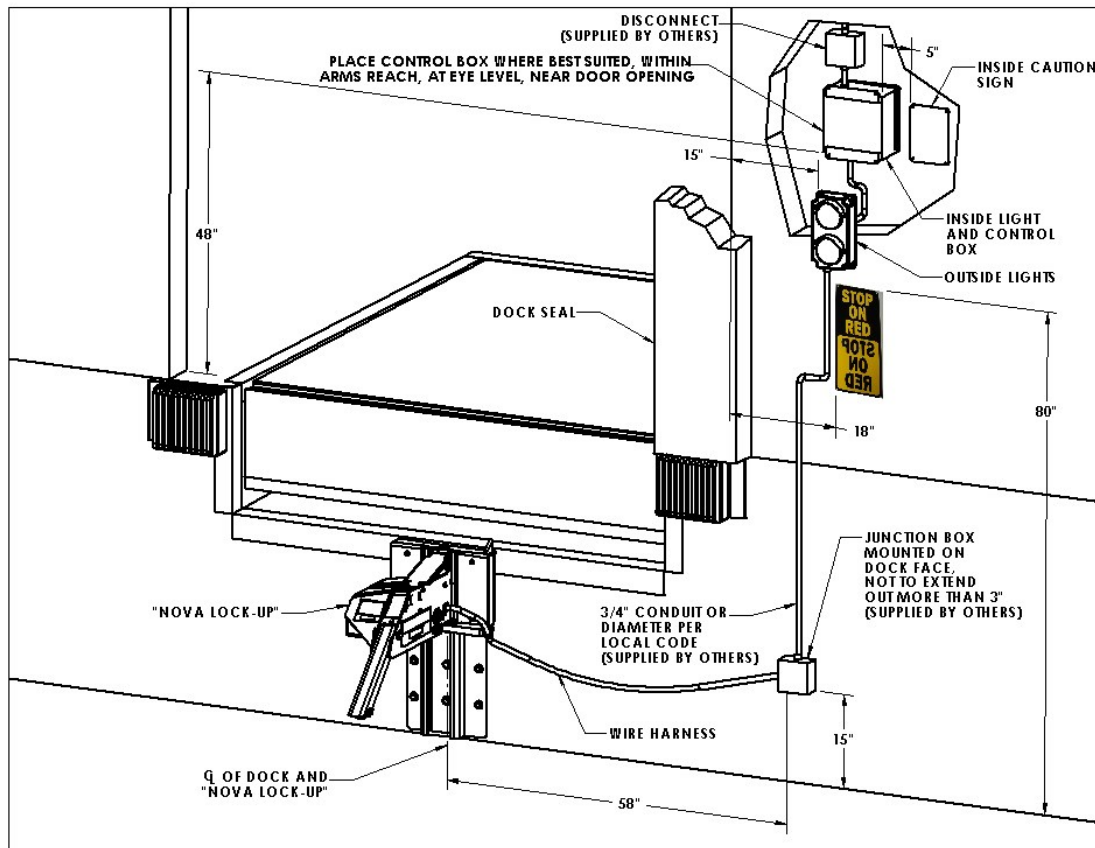

FIGURE H—SUGGESTED COMPONENT LOCATION

There is one (1) driver warning sign and one (1) inside operator sign supplied with each NOVA Lock-Up™ vehicle restraint. (*Mounting hardware supplied by others.*) Mount both outside signs on the right side of the NOVA Lock-Up™ vehicle restraint. The mirror-image sign is usually mounted above the lower sign and near the outside signal lights. (Mirror-image permits the truck driver to read sign from truck mirror.) Mount the inside sign next to the control box. Install all signs provided.

NOTES:

- Some docks may have dock/truck seals or shelters which are larger than standard. The outside light, sign location, and mounting should be studied before proceeding to avoid interference.
- If necessary, signs may be trimmed for fit. However, DO NOT cut or eliminate sign letters or words.

- Attach signs with concrete anchors or screws. Do not use nails.
- NEVER put conduit in front of signs. A clear view must be maintained at all times of both exterior signs and the single interior sign.

TEST OPERATION

Follow Operating Procedure in Owners Manual. Instruct dock workers on operating procedures.

WARRANTY

NOVA STANDARD PRODUCT WARRANTY

Nova Technology International, LLC (“Nova”) warrants that its products will be free from defects in design, materials and workmanship for a period of one (1) year from the date of shipment. All claims for breach of this warranty must be made within 30 days after the defect is or can with reasonable care, be detected. In no event shall any claim be made more than 30 days after this warranty has expired. In order to be entitled to the benefits of this warranty, the product must have been properly installed, maintained and operated in accordance with all manufacturer’s recommendations and/or specified design parameters and not otherwise have been subject to abuse, misuse, misapplication, acts of nature, overloading, unauthorized repair or modification, application in a corrosive environment or lack of maintenance. Periodic lubrication, adjustment and inspection in accordance with all manufacturers’ recommendations are the sole responsibility of the Owner/User.

In the event of a defect, as determined by Nova, covered by this warranty, Nova shall remedy such defect by repairing or replacing any defective equipment or parts, bearing the cost for the parts, labor and transportation. This shall be exclusive remedy for all claims whether based on contract, negligence or strict liability.

PRODUCT SPECIFIC WARRANTY NOVA Lock-Up™ Vehicle Restraint

In addition to the “Standard Product Warranty” provided with all Nova Products, Nova guarantees materials, components and workmanship to be free of defects for the following extended periods:

- Extended 2-year General Warranty—for a period of two (2) years from date of shipment, this warranty specifically applies to; the roller track assembly, carriage assembly, RIG sensor assembly and control box only.
- Extended 5-year Structural Warranty—for a period of five (5) years from the date of shipment, product will carry a prorated structural warranty. This warranty specifically applies to; the roller track, carriage weldment, motor cover, barrier assembly and lower spring bar only.

NOT COVERED UNDER WARRANTY

- Routine maintenance, lubrication, adjustments, including initial field set-up.
- Repairs required as a result of failure to follow routine maintenance procedures specified in the owner’s manual, abuse, accident, willful damage, neglect, improper installation, submersion, or shipping damage.

WARRANTY LIMITATIONS

The above warranties are in lieu of any other warranties, whether expressed or implied, including but not limited to and implied warranty of merchantability for a particular purpose. Nova and its subsidiaries shall not in any event be liable to anyone, including third parties, for incidental, consequential or special damages of any kind including but not limited to, breach of warranty, loss of use, loss of profit, interruption of business or loss of goodwill.



N90W14507 Commerce Drive Menomonee Falls, WI 53051
Phone 262-502-1591 | 800-236-7325 | fax 262-502-1511
www.novalocks.com