

# NOVA DEFENDER GATE™ 10

## ARCHITECTURAL DRAWING

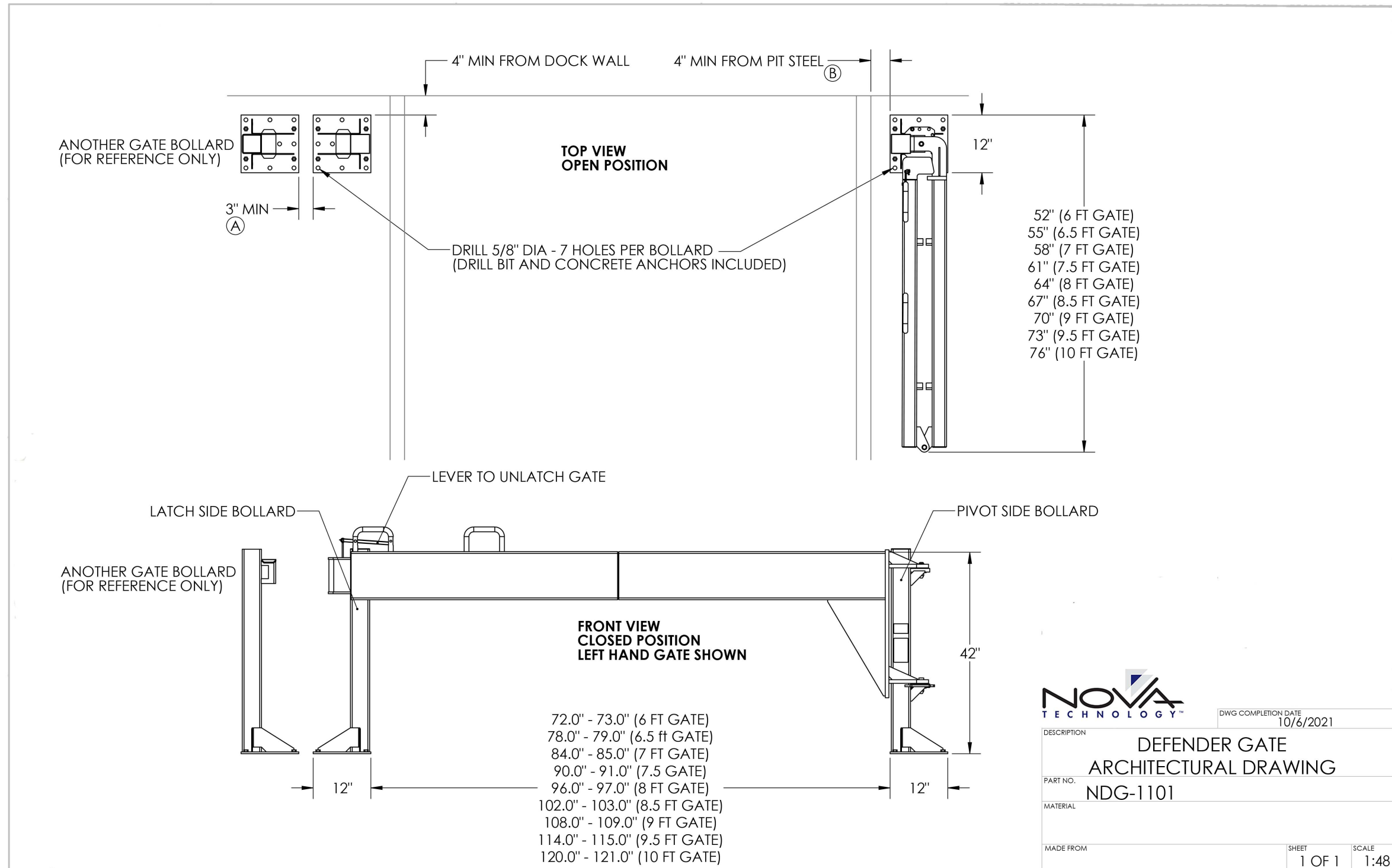

# NOVA DEFENDER GATE™ 10

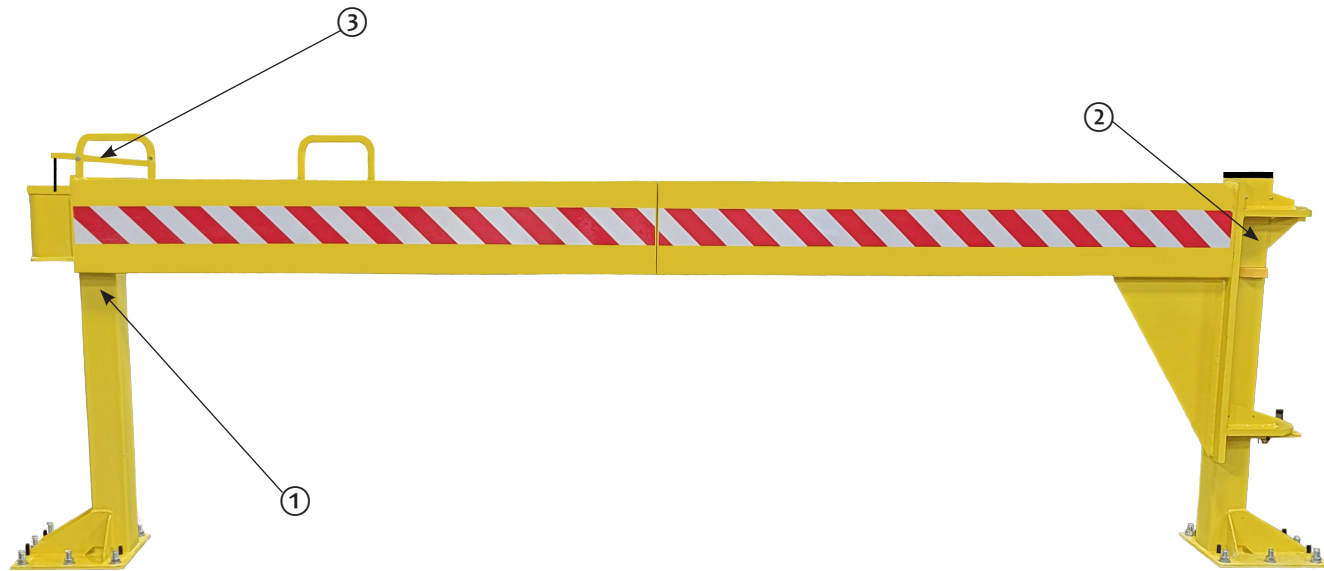

- 1 — LATCH SIDE BOLLARD
- 2 — PIVOT SIDE BOLLARD
- 3 — LEVER TO UNLATCH GATE

## STANDARD FEATURES

- Easy to operate with minimal effort
- Custom sizes and configurations available
- Ships in three pieces (all hardware included)
- Lockable latch (lock not included)
- Positive stop holds gate open without using moving parts
- Latch release on grab handle allows for faster, easier opening and closing

## OPTIONAL FEATURES

- Safety guard attachments
- Electronic interlock options available
- 21-inch Mid Rail attachment



 **WARNING:** Cancer and Reproductive Harm-[www.P65Warnings.ca.gov](http://www.P65Warnings.ca.gov)