



Vehicle Restraint Installation Manual

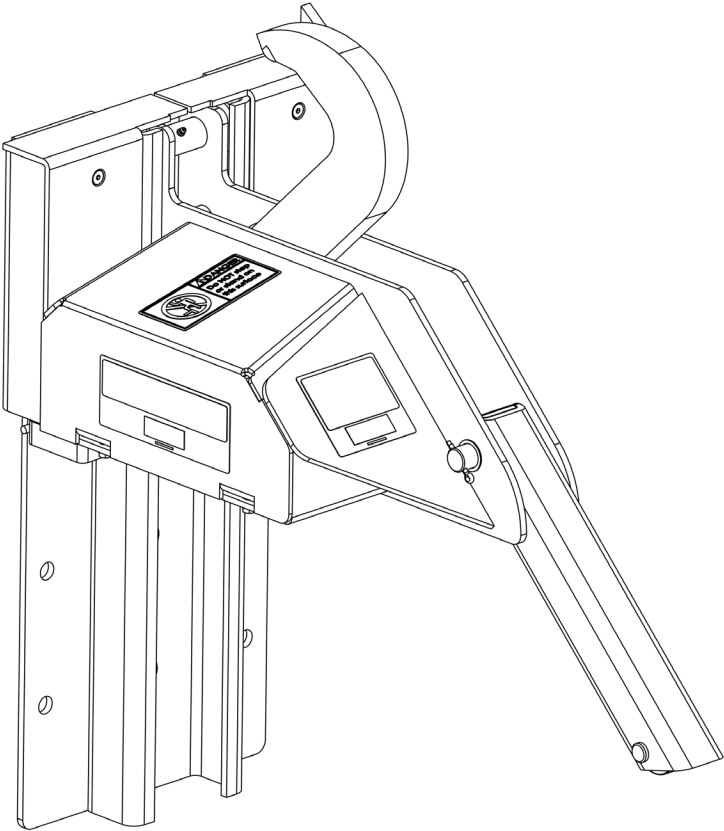

TABLE OF CONTENTS

SAFETY WARNINGS 3

INSTALLATION INSTRUCTIONS 7

WARRANTY..... 17

This page intentionally left blank.

SAFETY WARNINGS

Recognize Safety Information

Safety-Alert Symbol



The Safety-Alert Symbol is a graphic representation intended to convey a safety message without the use of words. When you see this symbol, be alert to the possibility of death or serious injury. Follow the instructions in the safety message panel.

DANGER

The use of the word DANGER signifies the presence of an extreme hazard or unsafe practice which will result in death or serious injury.

WARNING

The use of the word WARNING signifies the presence of a serious hazard or unsafe practice which could result in death or serious injury.

CAUTION

The use of the word CAUTION signifies possible hazard or unsafe practice which could result in minor or moderate injury.

NOTICE

NOTICE is used to address practices not related to physical injury.

SAFETY INSTRUCTIONS

Safety instruction (or equivalent) signs indicate specific safety-related instructions or procedures.

General Operational Safety Precautions

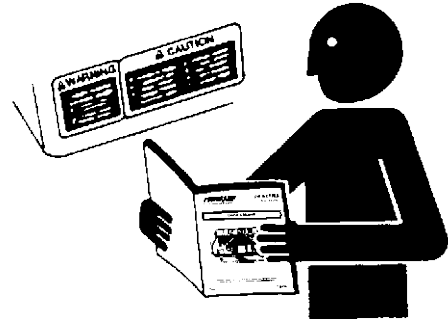

Read and understand the Owner's/User's Manual and become thoroughly familiar with the equipment and its controls before operating the transport vehicle restraint.

Never operate a transport vehicle restraint while a safety device or guard is removed or disconnected.

Never remove DANGER, WARNING, or CAUTION signs, Placards or Decal's on the equipment unless replacing them.

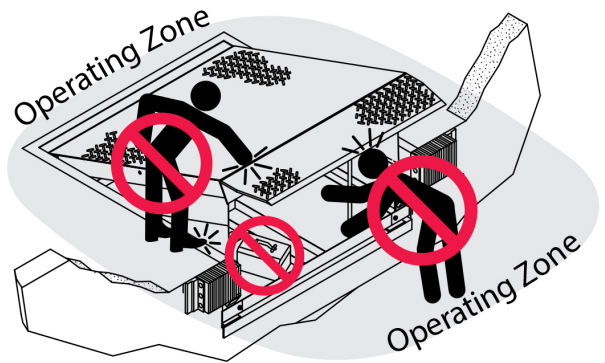

Do not start the equipment until all unauthorized personnel in the area have been warned and have moved outside the operating zone.

Remove any tools or foreign objects from the operating zone before starting.

Keep the operating zone free of obstacles that could cause a person to trip or fall.

SAFETY WARNINGS

Operational Safety Precautions



Learn the safe way to operate this equipment. Read and understand the manufacturer's instructions. If you have any questions, ask your supervisor.

DANGER



Stay clear of dock leveling device and restraint when transport vehicle is entering or leaving area.

Do not move or use the dock leveling device and restraint if anyone is under in front or near it.

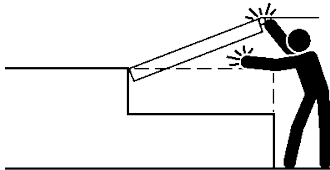

Keep hands and feet clear of pinch points. Avoid putting any part of your body near moving parts.

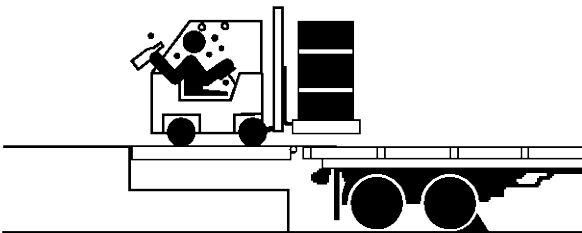

Do not operate any equipment while under the influence of alcohol or drugs.

Failure to follow these instructions will result in death or serious injury.

WARNING



Chock/restrain all transport vehicles. Never remove the wheel chocks until loading or unloading is finished and transport vehicles driver has been given permission to drive away.

Do not use a broken or damaged restraint device. Make sure proper service and maintenance procedures have been performed before using.

Failure to follow these instructions could result in death or serious injury.

SAFETY WARNINGS

Maintenance Safety Precautions

⚠ DANGER

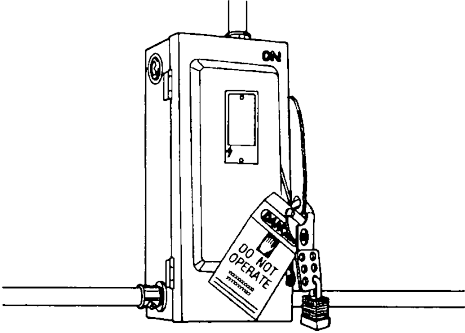

Electrical power must be OFF when servicing the equipment. For maximum protection, use an OSHA approved locking device to lock out all power sources. Only the person servicing the equipment should have the key to unlock the device.

Failure to follow these instructions will result in death or serious injury.

⚠ WARNING

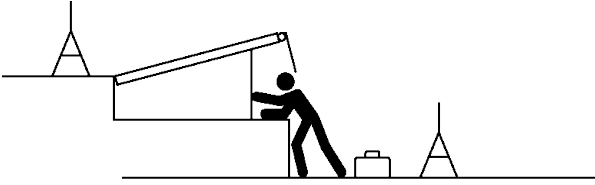

Always post safety warnings and barricade the work area at dock level and ground level to prevent unauthorized use of the unit before maintenance is complete.

Failure to follow these instructions could result in death or series injury.

⚠ DANGER

Arc Flash and Shock Hazard
PPE [Personal Protection Equipment] Required

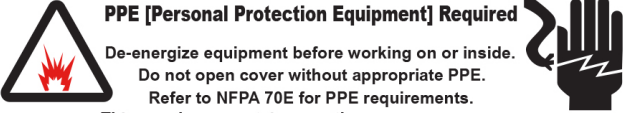

De-energize equipment before working on or inside.
 Do not open cover without appropriate PPE.
 Refer to NFPA 70E for PPE requirements.
 This panel may contain more than one power source.

MF2-202-000

Hazardous Voltage Will Result in Death or Serious Injury

⚠ WARNING

ALWAYS disconnect electrical power source and ground wire before welding on restraint.

DO NOT ground welding equipment to any electrical components of the restraint. Always ground to the restraint frame.

Failure to follow these instructions could result in death or serious injury and/or damage to restraint.

⚠ WARNING

DO NOT grind or weld if hydraulic fluid or other flammable liquid is present on the surface to be ground or welded.

DO NOT grind or weld if uncontained hydraulic fluid or other flammable liquid is present. Stray sparks can ignite spills or leaks near the work area. Always clean up the oil leaks and spills before proceeding with grinding or welding.

Always keep a fire extinguisher of the proper type nearby when grinding or welding.

Failure to follow these instructions could result in death or serious injury.

This page intentionally left blank.

INSTALLATION INSTRUCTIONS

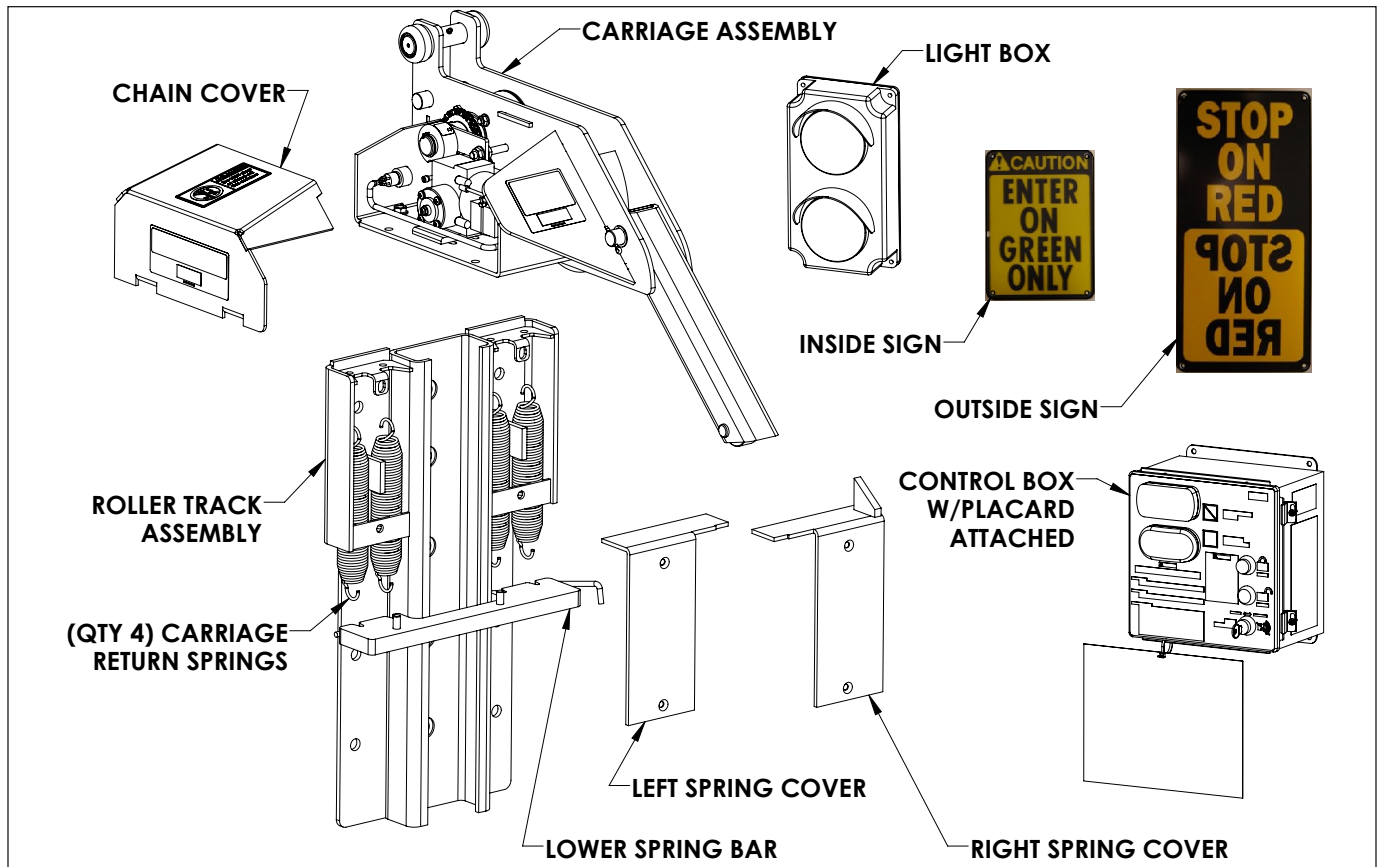

FIGURE A—LOCK & LOAD COMPONENTS DESCRIPTION

NOTICE

A 4" thick bumper is required regardless of whether or not there is a leveler. **DO NOT** install a Lock & Load vehicle restraint on docks without 4" thick bumpers. For thicker bumpers consult factory.

INSTALLATION INSTRUCTIONS

A Lock & Load vehicle restraint may be installed on docks with or without levelers; consult NOVA for proper application.

Follow the simple installation procedures below:

- Inspect Lock & Load vehicle restraint parts.
- Install roller track plate.
- Install Lock & Load vehicle restraint into roller track plate.
- Install electrical components.
- Install safety & instruction signs.
- Test operation.

DANGER

Post safety warnings and barricade work area, at dock level and at ground level, to prevent unauthorized use of the dock position.

INSPECT LOCK & LOAD PARTS

Open packaging and inspect all parts and materials—see Figure A above. Immediately report any damage or missing materials to factory. Review the component assemblies to determine their correct locations.

INSTALLATION INSTRUCTIONS (continued)

INSTALL ROLLER TRACK PLATE

Install roller track plate onto dock face at specified location by welding to an embedded steel plate or by using the fifteen (15) concrete anchors provided in conjunction with welding to pit steel and a leveler frame. Refer to Figures B and C.

If you have questions, contact NOVA Technical Support at (800) 236-7325.

NOTICE

The roller track plate must be plumb with dock face. If not, use and weld (6) shims 2" wide x 25 5/8" long. If shims are over 1/2" thick use longer anchors. If shims need to be 1" thick or more, contact NOVA.

If the dock face is not perpendicular, contact NOVA Technical Support at (800) 236-7325.

The carriage roller track cannot be bent or deformed. Straighten or replace if necessary.

NOTE: Trim roller track plate, as necessary, up to a maximum of 5" from the bottom.

NOTE: Some mechanical dock levelers have an adjusting nut access hole in the leveler front subframe. If the Lock & Load vehicle restraint roller track interferes with the access hole, the track plate must be cut to allow access.

NOTE: Some levelers are slightly recessed within the pit and thus require a shim to be inserted between the roller track plate and the leveler front subframe and welded in place.

NOTICE

Fifteen (15) concrete anchors are provided with each Lock & Load vehicle restraint. An anchor must be installed in each roller track plate hole except for those plug-welded to embedded steel.

ANCHOR INSTALLATION INSTRUCTIONS

1. Put roller track plate in place.
2. Drill hole of 5/8" diameter and minimum of 4-5/8" deep. Clean out hole.
3. Insert anchor and drive flush with roller track plate, making sure that the threaded wedge is inserted first. Do not disassemble anchor prior to installation.
4. Install all anchors and torque to 100 ft-lbs. See figure B.

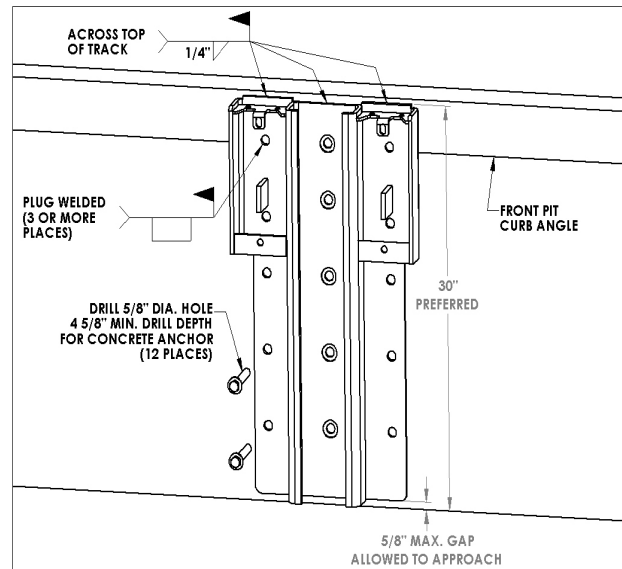

FIGURE B—ANCHORING ROLLER TRACK PLATE

INSTALLATION INSTRUCTIONS *(continued)*

WELDING INSTALLATION INSTRUCTIONS

If the installation being worked on is a retrofit or replacement situation, the following electrical connections must be disconnected prior to welding.

LOCKOUT/TAGOUT the power at the fused disconnect, then remove the motor and limit switch connections from the control harness located in the outside junction box. Once all welding has been completed, reconnect all the wires.

NOTES:

- Never install the Lock & Load vehicle restraint directly onto concrete block or brick dock face.
- When welding the Lock & Load vehicle restraint, disconnect power and ground leads to leveler.
- Due to actual conditions, total mounting height may be different.
- Plug weld all holes that are in contact with the embedded mounting plate. All fifteen (15) holes must be either plug welded or anchored. See figure C.
- Shims must be the full length of the roller track mounting plate. Minimum electrode must be 1/8" 7018 or better. See figure D.

NOTICE

Never weld on the Lock & Load vehicle restraint after the motor is wired into the control box and power to the control box is on. Electrical current from the welder can loop back through the circuit and damage the motor and other components.

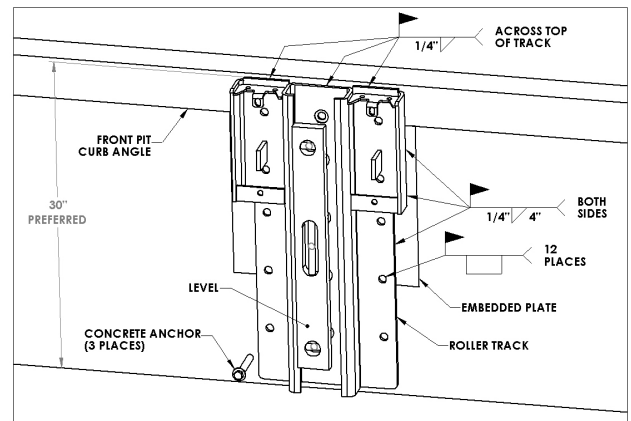

FIGURE C—WELDING ROLLER TRACK FRONT VIEW (WITH EMBEDDED PLATE)

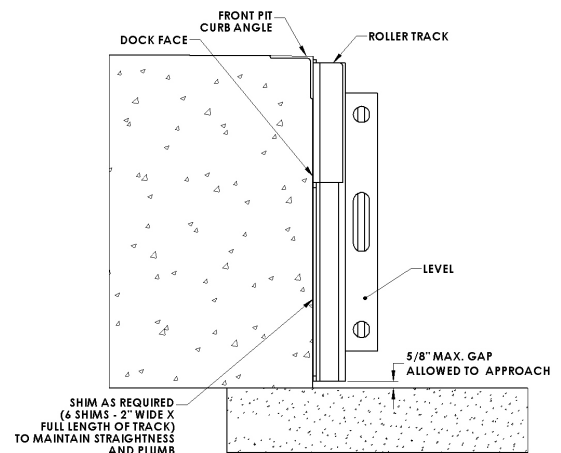

FIGURE D—WELDING ROLLER TRACK SIDE VIEW

INSTALLATION INSTRUCTIONS *(continued)*

INSTALL VEHICLE RESTRAINT INTO ROLLER TRACK PLATE

CAUTION

Use lifting device (e.g. crane, jack) when lifting carriage (approx. 110 lbs.). Lifting by hand may cause back injury.

- Attach the four (4) springs to the lower spring bar.
- Pull springs upward and slide over top spring mount on the track roller plate.
- Install right and left spring cover with clip nuts and flat head screws provided.
- Slide the carriage assembly into the roller track. Refer to Figure E.
- Position and bolt the lower spring bar to the bottom of the Lock & Load vehicle restraint carriage.
- Install the motor cover and spring covers.
- Install slope extension.

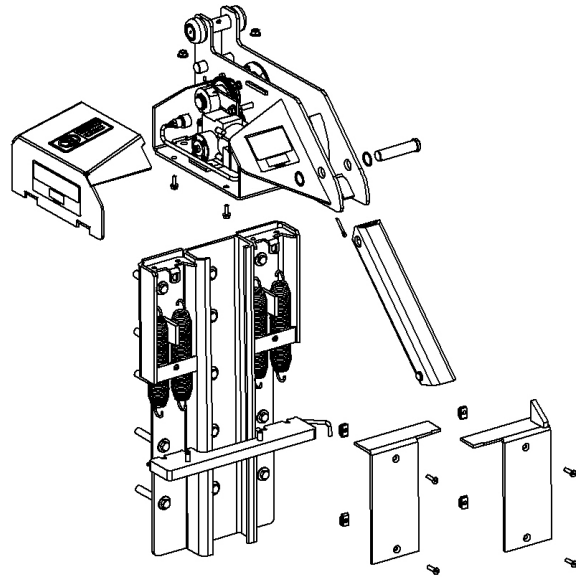

FIGURE E

INSTALLATION INSTRUCTIONS *(continued)*

INSTALL ELECTRICAL COMPONENTS

DANGER

Make sure that the power source has been locked out and tagged according to OSHA regulations and approved local electrical codes.

If the incoming electrical power for the Lock & Load vehicle restraint is taken from a nearby electrical appliance, e.g., overhead door opener, verify that the amperage is in accordance with local and federal codes.

The Lock & Load vehicle restraint 1/10 HP motor requires 120V, single phase power, 60 Hz power and 10 amps of current to operate properly.

Two (2) Lock & Load vehicle restraints can be connected into one (1) 20 amp branch circuit breaker per the 1999 National Electrical Code Paragraph 430-53.

If you have questions, contact NOVA Technical Support at (800) 236-7325.

NOTICE

Where indicated, all components must be connected to a SAFETY EARTH GROUND that conforms to the 1999 National Electric Code Section 250-50 section (a) or section (c) for a grounding electrode system.

The Lock & Load vehicle restraint assembly includes a 63" long flexible wiring harness, the control box with lights and the outside signal light box. The outside junction box, conduit fittings and wire are provided by others; be sure to use a qualified installer utilizing quality materials. Refer to Figures F and G.

Refer to Figure H, page 10 for component location information. Electrical schematics for wiring information can be found inside the control box.

CONTROL BOX INSTALLATION GUIDELINES—TEMPERATURE CONTROLLED APPLICATIONS.

1. Route the conduit to enter through the side or bottom of the enclosure. If the conduit could fill with water, a drip leg may be needed.
2. Seal the conduit in any location where the conduit crosses over temperature zones that could produce condensation.
3. Install spacers between the wall and enclosure to provide temperature insulation and air flow.

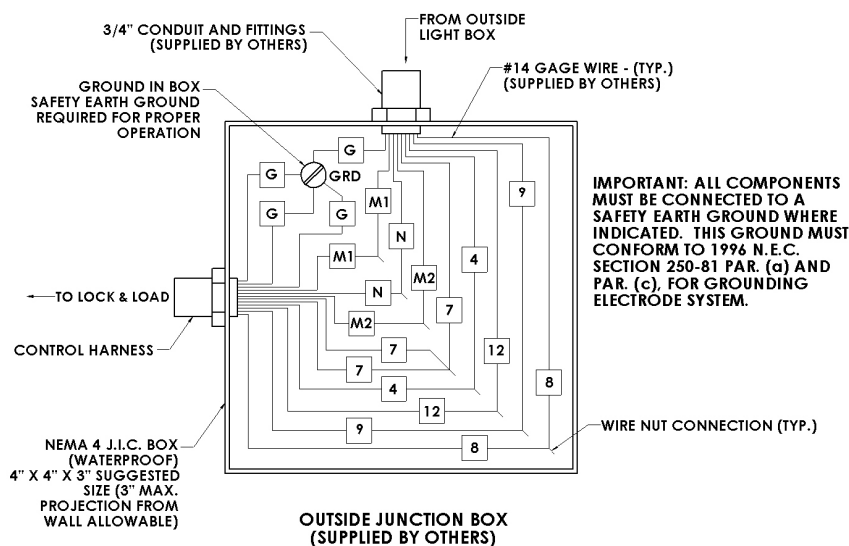

FIGURE F—OUTSIDE JUNCTION BOX

INSTALLATION INSTRUCTIONS *(continued)*

INSTALL ELECTRICAL COMPONENTS *(continued)*

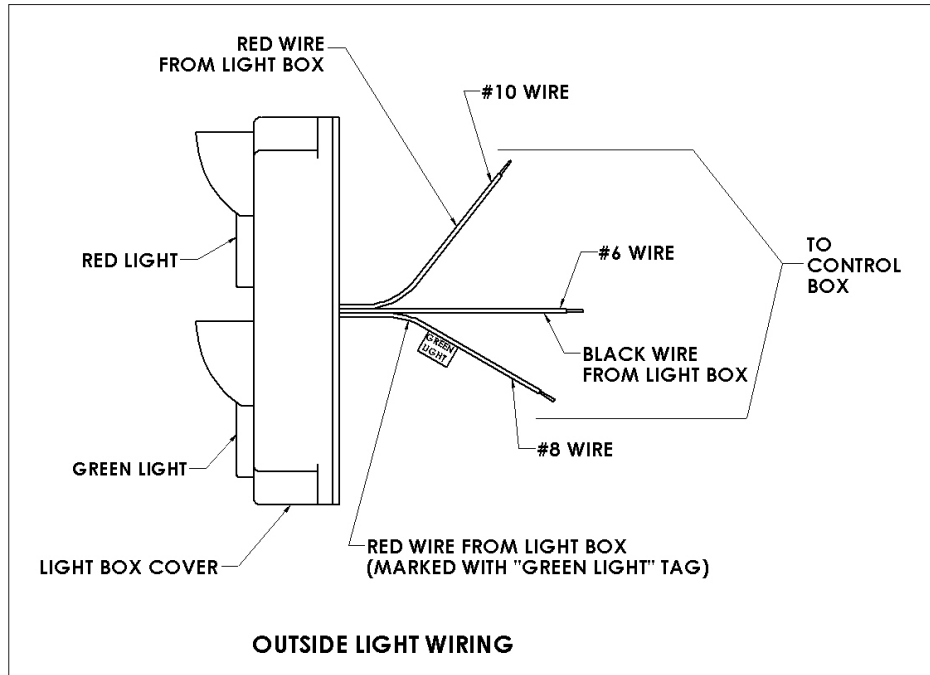

FIGURE G—OUTSIDE LIGHT WIRING

INSTALLATION INSTRUCTIONS *(continued)*

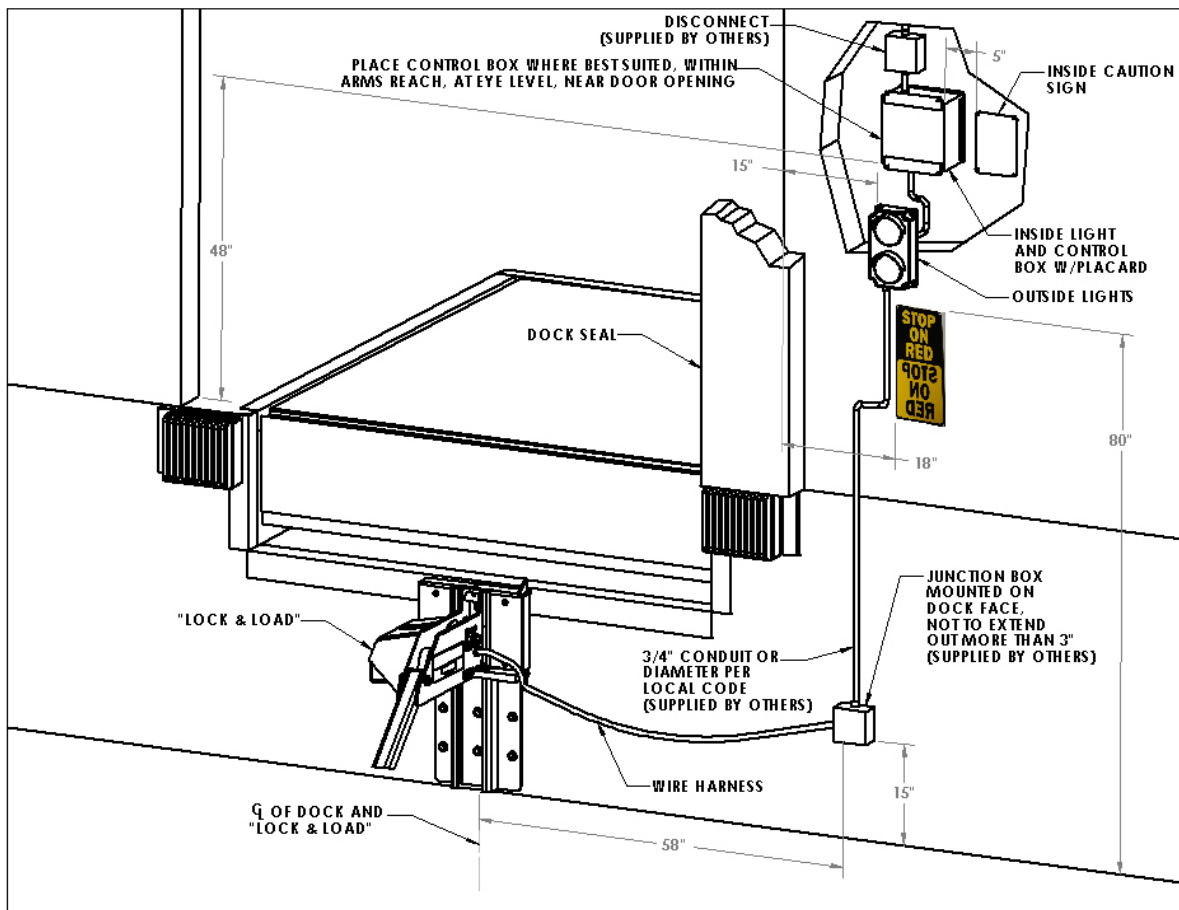

FIGURE H—SUGGESTED COMPONENT LOCATION

There is one (1) driver warning sign and one (1) inside operator sign supplied with each Lock & Load vehicle restraint. (Mounting hardware supplied by others.) Mount both outside signs on the right side of the Lock & Load vehicle restraint. The mirror-image sign is usually mounted above the lower sign and near the outside signal lights. (Mirror-image permits the truck driver to read sign from truck mirror.) Mount the inside sign next to the control box. Install all signs provided.

NOTES:

- Some docks may have dock/truck seals or shelters which are larger than standard. The outside light, sign location, and mounting should be studied before proceeding to avoid interference.
- If necessary, signs may be trimmed for fit. However, DO NOT cut or eliminate sign letters or words.

- Attach signs with concrete anchors or screws. Do not use nails.
- NEVER put conduit in front of signs. A clear view must be maintained at all times of both exterior signs and the single interior sign.

TEST OPERATION

Follow Operating Procedure in Owners Manual. Instruct dock workers on operating procedures.

This page intentionally left blank.

This page intentionally left blank.

This page intentionally left blank.

WARRANTY

NOVA TECHNOLOGY INTERNATIONAL, LLC warrants that its products will be free from defects in design, materials and workmanship for a period of one (1) year from the date of shipment. All claims for breach of this warranty must be made within 30 days after the defect is or can with reasonable care, be detected. In no event shall any claim be made more than 30 days after this warranty has expired. In order to be entitled to the benefits of this warranty, the product must have been properly installed, maintained and operated in accordance with all manufacturer's recommendations and/or specified design parameters and not otherwise have been subject to abuse, misuse, misapplication, acts of nature, overloading, unauthorized repair or modification, application in a corrosive environment or lack of maintenance. Periodic lubrication, adjustment and inspection in accordance with all manufacturers' recommendations are the sole responsibility of the Owner/User.

In the event of a defect, as determined by NOVA TECHNOLOGY INTERNATIONAL, LLC, covered by this warranty, NOVA TECHNOLOGY INTERNATIONAL, LLC shall remedy such defect by repairing or replacing any defective equipment or parts, bearing the cost for the parts, labor and transportation. This shall be exclusive remedy for all claims whether based on contract, negligence or strict liability.

PRODUCT SPECIFIC WARRANTY LOCK & LOAD VEHICLE RESTRAINT

In addition to the "Standard Product Warranty" provided with all Nova Products, NOVA TECHNOLOGY INTERNATIONAL, LLC guarantees materials, components and workmanship to be free of defects for the following extended periods:

- Extended 2-Year General Warranty—for a period of two (2) years from date of shipment, this warranty specifically applies to; the roller track assembly, carriage assembly, and control box only.
- Extended 5-Year Structural Warranty—for a period of five (5) years from date of shipment, product will carry a prorated structural warranty. This warranty specifically applies to; the roller track, carriage weldment, chain cover, straight hook, and lower spring bar only.

NOT COVERED UNDER WARRANTY

- Routine maintenance, lubrication, adjustments, including initial field set-up.
- Repairs required as a result of failure to follow routine maintenance procedures specified in the owner's manual, abuse, accident, willful damage, neglect, improper installation, submersion, or shipping damage.

WARRANTY LIMITATIONS

THE ABOVE WARRANTIES ARE IN LIEU OF ANY OTHER WARRANTIES, WHETHER EXPRESSED OR IMPLIED, INCLUDING BUT NOT LIMITED TO ANY IMPLIED WARRANTY OF MERCHANTABILITY OR FITNESS FOR A PARTICULAR PURPOSE. NOVA TECHNOLOGY INTERNATIONAL, LLC AND ITS SUBSIDIARIES SHALL NOT IN ANY EVENT BE LIABLE TO ANYONE, INCLUDING THIRD PARTIES, FOR INCIDENTAL, CONSEQUENTIAL OR SPECIAL DAMAGES OF ANY KIND INCLUDING BUT NOT LIMITED TO, BREACH OF WARRANTY, LOSS OF USE, LOSS OF PROFIT, INTERRUPTION OF BUSINESS OR LOSS OF GOODWILL.



N90W14507 Commerce Drive Menomonee Falls, WI 53051
Phone 262-502-1591 | 800-236-7325 | fax 262-502-1511
www.novalocks.com