

# NOVA PEDESTRIAN GATE (SPLIT)

## ARCHITECTURAL DRAWING

DIMENSION A	DIMENSION B	DIMENSION C
6'	105.5"	85"
6'-6"	111.5"	88"
7'	117.5"	91"
7'-6"	123.5"	94"
8'	129.5"	97"
8'-6"	135.5"	100"
9'	141.5"	103"
9'-6"	147.5"	106"
10'	153.5"	109"
10'-6"	159.5"	112"
11'	165.5"	115"
11'-6"	171.5"	118"
12'	177.5"	121"
12'-6"	183.5"	124"
13'	189.5"	127"
13'-6"	195.5"	130"
14'	201.5"	133"

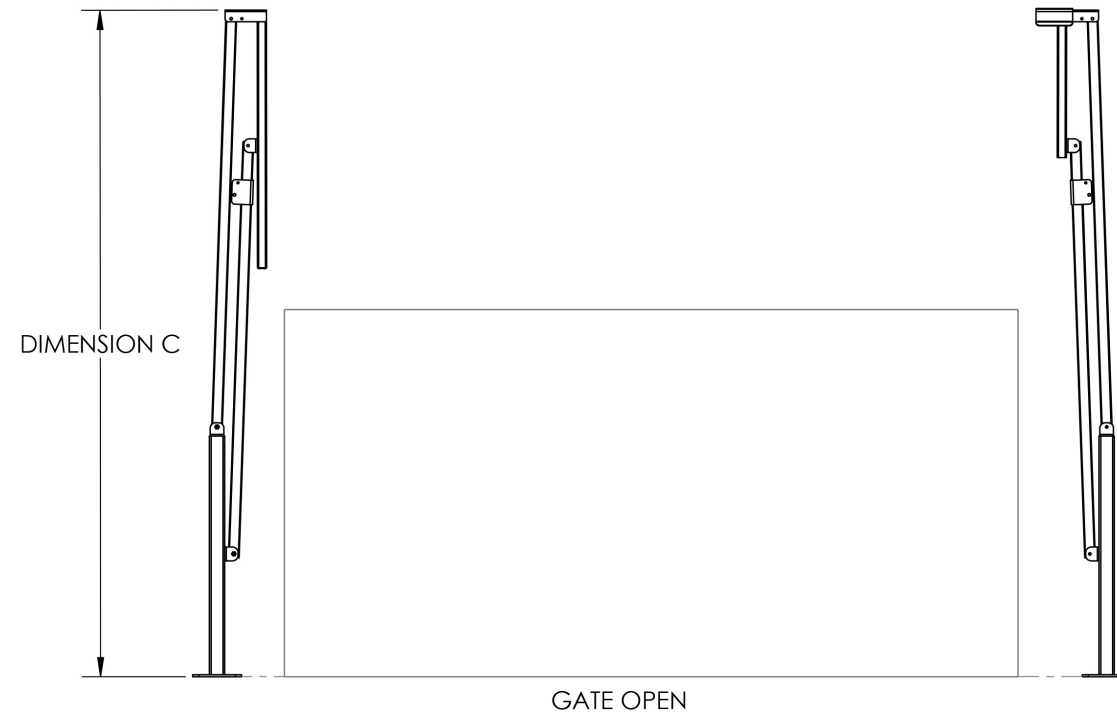
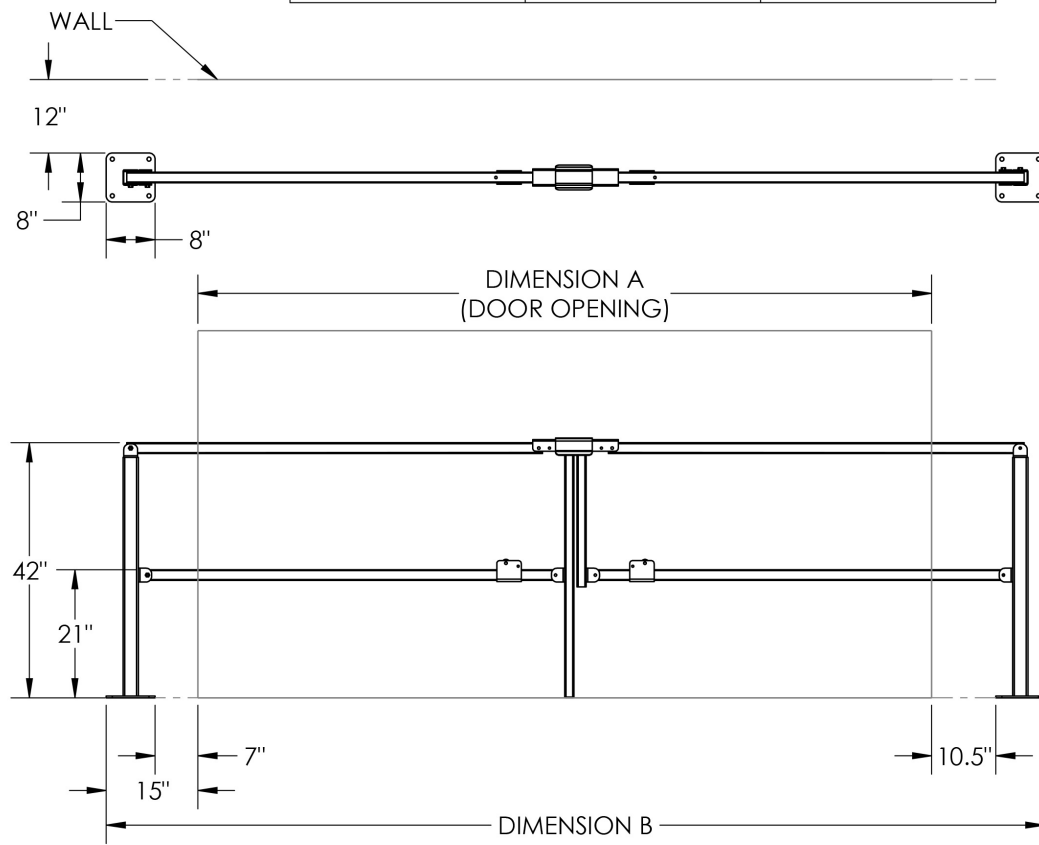

W141N9240 FOUNTAIN BLVD., MENOMONEE FALLS, WI, 53051

GEOMETRIC DIMENSIONING AND TOLERANCING PER ASME Y14.5M

THIRD ANGLE PROJECTION

ALL INFORMATION CONTAINED IN THIS DOCUMENT IS PROPERTY OF NOVA TECHNOLOGY AND MAY NOT BE REPRODUCED IN WHOLE OR PART, WITHOUT WRITTEN CONSENT OF NOVA TECHNOLOGY

UNLESS OTHERWISE SPECIFIED:  
 DIMENSIONS ARE IN INCHES  
 DIMENSIONS IN [ ] ARE IN MILLIMETERS  
 TOLERANCES:  
 FRACTIONAL: ±.030  
 ANGLES: ±1 DEGREE  
 ONE PLACE DECIMAL: ±.100  
 TWO PLACE DECIMAL: ±.020  
 THREE PLACE DECIMAL: ±.005  
 BREAK ALL SHARP EDGES .010 MAX.  
 REMOVE ALL BURRS.  
 REMOVE ALL WELD BB'S AND SPATTER

DWG COMPLETION DATE  
2/20/25

DESCRIPTION  
**SPLIT PEDESTRIAN GATE**  
**ARCHITECTURAL DRAWING**

# NOVA PEDESTRIAN GATE (SPLIT)

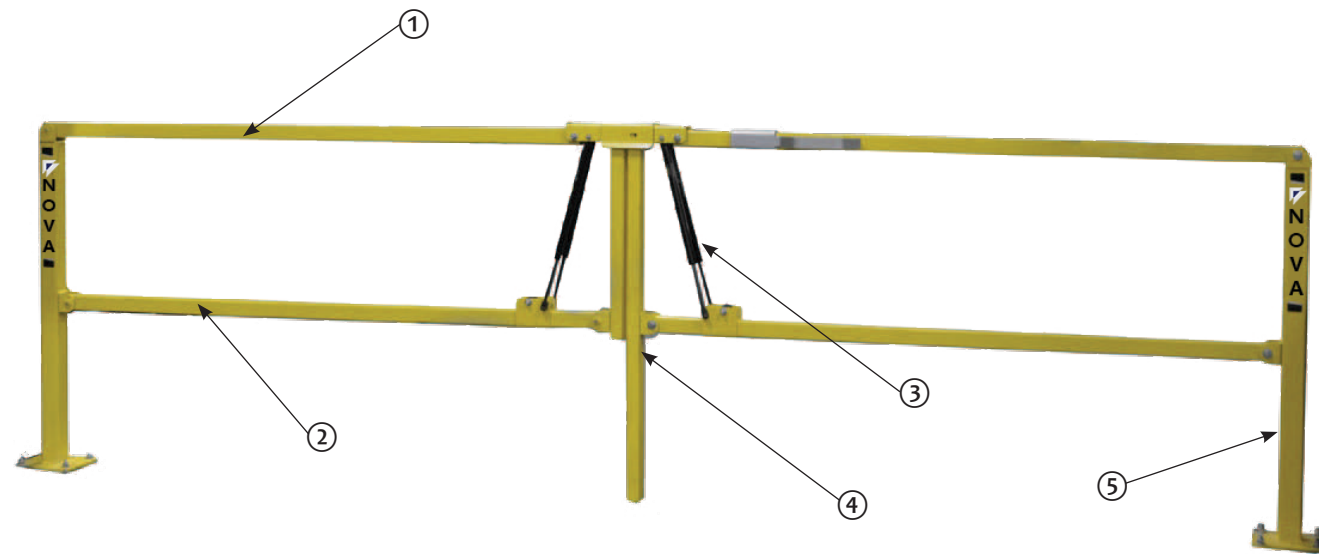

Split opening gates for openings 6 ft. to 14 ft. wide

1 — UPPER GUARDRAIL  
2 — LOWER GUARDRAIL  
3 — DUAL GAS STRUTS

4 — CENTER SUPPORT  
5 — BOLLARD

## STANDARD FEATURES

- Meets OSHA guidelines for fall protection
- Easily opens upward with minimal effort
- One foot increments standard
- Split opening cantilever style accommodates wider openings & lower ceiling heights
- Latching mechanism locks the gate in the down position
- Gate automatically engages the Spring Plunger when closed
- Split gates lock together at the center in the closed position for added strength
- Concrete anchors and all hardware included

## OPTIONAL FEATURES

- Optional lock for access control
- Custom sizes available



 **WARNING:** Cancer and Reproductive Harm-[www.P65Warnings.ca.gov](http://www.P65Warnings.ca.gov)